

- Carefully pull both sides of the monitor stand's base as shown in the diagram.

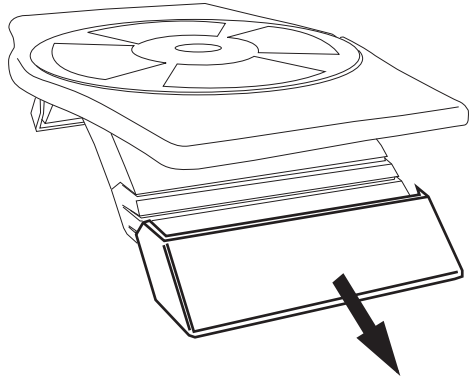

- Once the base is released, slide the base horizontally outwards.

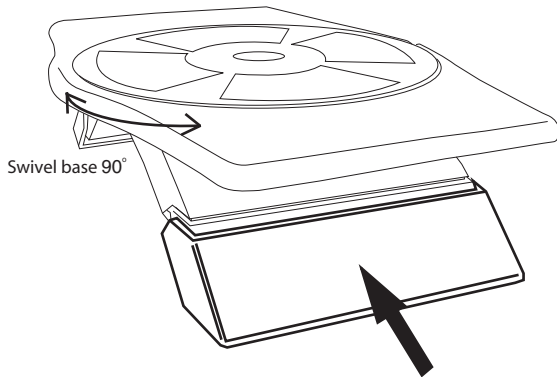

- Adjust the stand to a comfortable height and slide the base back until it locks into place.

Technical Support

For technical questions, please visit:

US Internet: www.targus.com/support.asp

Australia Internet: www.targus.com.au

Email: infoaust@targus.com

Telephone: 1800-641-645

New Zealand Telephone: 0800-633-222

Product Registration

Targus recommends that you register your Targus accessory shortly after purchasing it. Go to:

<http://www.targus.com/registration.asp>. You will need to provide your full name, email address, phone number, and company information (if applicable).

Warranty

Targus warrants this product to be free from defects in materials and workmanship for one year. If your Targus accessory is found to be defective within that time, we will promptly repair or replace it. This warranty does not cover accidental damage, wear and tear, or consequential or incidental loss. Under no conditions is Targus liable for loss of, or damage to a devices nor loss of, or damage to, programs, records, or data; nor any consequential or incidental damages, even if Targus has been informed of their possibility. This warranty does not affect your statutory rights.